

Litra Habbillns 1999

2780 400 - 414 1999 Niesky & TVP - fabriksnumre findes i vognlisten

2780 650 - 684 1999 Niesky & TVP - fabriksnumre findes i vognlisten

= 50 godsvogne type H 99a - Indlejet fra AAE (AAE type H3)

Beskrivelse og historik

Bogieskydevægsvogne med 8 flytbare skillevægge anskaffet i stort antal af AAE med udlejning for øje. DSB indlejede 1999 i alt 50 nybyggede vogne af denne AAE type H3. DSB gods havde muligvis overvurderet behovet, for allerede i 2002 sendtes 15 vogne retur til AAE, og resten fulgte efter i 2005.

Data**H 99a**

Længde over puffer	23264 mm
Understel længde	22024 mm
Bogiecenterafstand	17724 mm (b)
Bogier	Y25/TVP
Akselafstand bogie	1800 mm
Læsselængde	21300 mm
Læssebredde	2840 mm
Bundfladeareal	60,5 m ²
Indv højde sidevæg	2100 mm
Indv højde gavlvæg	2800 mm
Rumfang	162,0 m ³
Sidedør bredde	2x 10810 mm
Sidedør højde	2800 mm
Gulvhøjde	1200 mm
Håndbremse	PS (a)
- bremsevægt	22,0 t
Automatisk bremse	KE-GP-A
- bremsevægt	Max 59t
Max hastighed	120 km/h
Taravægt ca	28500 kg
Lastgrænse UIC	

	A	B	C	D	
S	35,5	43,5	53,5	61,5	★★
120	0,00				

a) Det formodes, at alle vogne har P-skruerbremse. Ihvertfald er ingen observeret uden.

b) Påmalet 17,70 m.

Vognliste

- se side Habbillns 1.51 ff

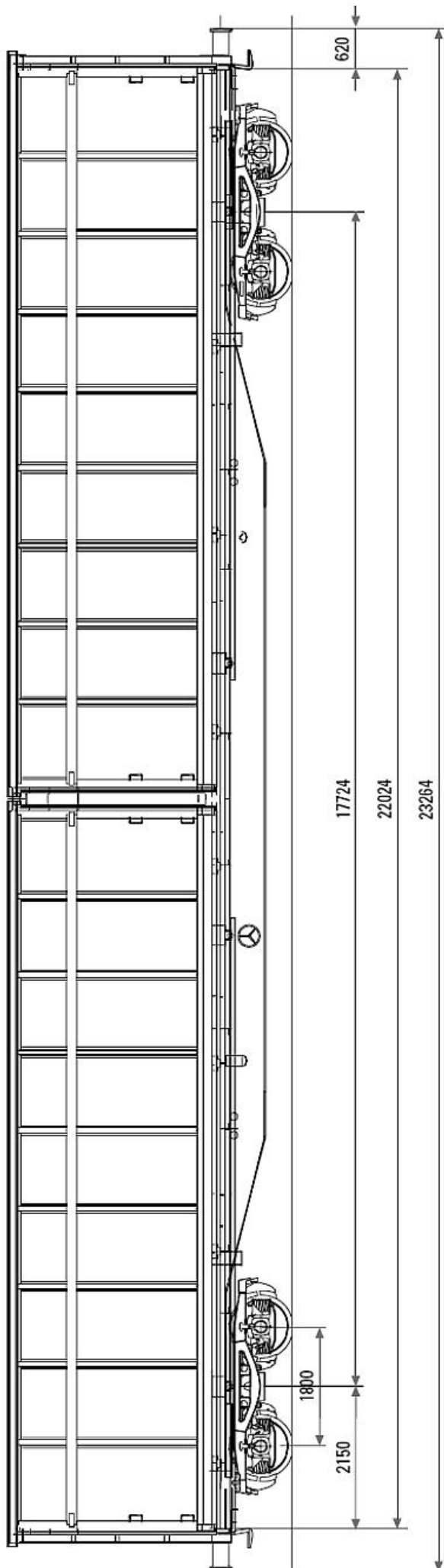

AAE type H3 - Tegning tilnærmet skala 1:87 / H0

fra http://www.aae.ch/upload/db_habbillns.pdf

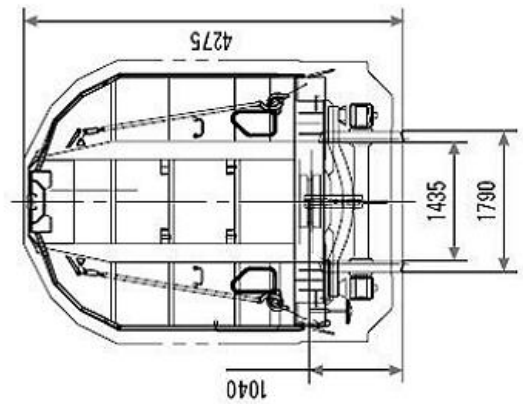



31 86 2780402-0 Habbillns nyleveret, København Gb 13.02.1999 © Per Topp Nielsen



31 86 2780404-6 Habbillns nyleveret, København Gb 06.02.1999 © Per Topp Nielsen



31 86 2780678-5 Habbillns, Nykøbing Falster 03.04.2000 © Per Topp Nielsen



31 80 2780672 Habbillns AAE, Kbh Gb 16.10.1999 © P.T.Nielsen

31 86 2780672-8 Habbillns nyleveret, København Gb 16.10.1999 © Per Topp Nielsen



31 86 2780680-1 Habbillns, Nakskov 19.06.2002 © Per Topp Nielsen

31-86-	litra	TVP	Niesky	tilg.	REV	udg.	senere
2780 400 -4	Habbillns	1998-99	38955-99	1999	28-01-1999	2002	retur > AAE
2780 401 -2	Habbillns	1983-98	38940-99	1999	28-01-1999	2002	retur > AAE
2780 402 -0	Habbillns	1978-98	38935-99	1999	28-01-1999	2002	retur > AAE
2780 403 -8	Habbillns	1969-98	38926-99	1999	29-01-1999	2002	retur > AAE
2780 404 -6	Habbillns	1970-99	38927-99	1999	29-01-1999	2002	retur > AAE
2780 405 -3	Habbillns	1967-98	38924-99	1999	03-02-1999	2002	retur > AAE
2780 406 -1	Habbillns	1979-98	38936-99	1999	29-01-1999	2002	retur > AAE
2780 407 -9	Habbillns	1987-99	38944-99	1999	01-02-1999	2002	retur > AAE
2780 408 -7	Habbillns	1968-98	38925-99	1999	26-02-1999	2002	retur > AAE
2780 409 -5	Habbillns	2002-99	39234-99	1999	24-02-1999	2002	retur > AAE
2780 410 -3	Habbillns	1926-98	38883-99	1999	25-02-1999	2002	retur > AAE
2780 411 -1	Habbillns	2000-99	38957-99	1999	23-02-1999	2002	retur > AAE
2780 412 -9	Habbillns	1980-99	38937-99	1999	26-02-1999	2002	retur > AAE
2780 413 -7	Habbillns	2003-99	39232-99	1999	26-02-1999	2002	retur > AAE
2780 414 -5	Habbillns	1996-99	38953-99	1999	23-02-1999	2002	retur > AAE
2780 650 -4	Habbillns	2309-99	39470-99	1999	04-10-1999	2005	retur > AAE
2780 651 -2	Habbillns	2321-99	39482-99	1999	24-09-1999	2005	retur > AAE
2780 652 -0	Habbillns	2286-99	39447-99	1999	27-09-1999	2005	retur > AAE
2780 653 -8	Habbillns	2314-99	39475-99	1999	05-10-1999	2005	retur > AAE
2780 654 -6	Habbillns	2216-99	39377-99	1999		2005	retur > AAE
2780 655 -3	Habbillns	2304-99	39465-99	1999	16-09-1999	2005	retur > AAE
2780 656 -1	Habbillns	2316-99	39477-99	1999	05-10-1999	2005	retur > AAE
2780 657 -9	Habbillns	2311-99	39472-99	1999	05-10-1999	2005	retur > AAE
2780 658 -7	Habbillns	2302-99	39463-99	1999	05-10-1999	2005	retur > AAE
2780 659 -5	Habbillns	2315-99	39476-99	1999	16-09-1999	2005	retur > AAE
2780 660 -3	Habbillns	2218-99	39379-99	1999	04-10-1999	2005	retur > AAE
2780 661 -1	Habbillns	2220-99	39381-99	1999	04-10-1999	2005	retur > AAE
2780 662 -9	Habbillns	2287-99	39448-99	1999	05-10-1999	2005	retur > AAE
2780 663 -7	Habbillns	2303-99	39464-99	1999	05-10-1999	2005	retur > AAE
2780 664 -5	Habbillns	2328-99	39489-99	1999	16-09-1999	2005	retur > AAE
2780 665 -2	Habbillns	2240-99	39401-99	1999	23-09-1999	2005	retur > AAE
2780 666 -0	Habbillns	2327-99	39488-99	1999	22-09-1999	2005	retur > AAE
2780 667 -8	Habbillns	2326-99	39487-99	1999	05-10-1999	2005	retur > AAE
2780 668 -6	Habbillns	2335-99	39496-99	1999	21-09-1999	2005	retur > AAE
2780 669 -4	Habbillns	2329-99	39490-99	1999	21-09-1999	2005	retur > AAE
2780 670 -2	Habbillns	2323-99	39484-99	1999	22-09-1999	2005	retur > AAE
2780 671 -0	Habbillns	2337-99	39498-99	1999	22-09-1999	2005	retur > AAE
2780 672 -8	Habbillns	2331-99	39492-99	1999	23-09-1999	2005	retur > AAE
2780 673 -6	Habbillns	2334-99	39495-99	1999	24-09-1999	2005	retur > AAE
2780 674 -4	Habbillns	2336-99	39497-99	1999	24-09-1999	2005	retur > AAE
2780 675 -1	Habbillns	2330-99	39491-99	1999	24-09-1999	2005	retur > AAE
2780 676 -9	Habbillns	2325-99	39486-99	1999	27-09-1999	2005	retur > AAE
2780 677 -7	Habbillns	2291-99	39452-99	1999	04-10-1999	2005	retur > AAE
2780 678 -5	Habbillns	2342-99	39503-99	1999	05-10-1999	2005	retur > AAE
2780 679 -3	Habbillns	2332-99	39493-99	1999	05-10-1999	2005	retur > AAE
2780 680 -1	Habbillns	2293-99	39454-99	1999	30-09-1999	2005	retur > AAE
2780 681 -9	Habbillns	2299-99	39460-99	1999	30-09-1999	2005	retur > AAE
2780 682 -7	Habbillns	2301-99	39462-99	1999	04-10-1999	2005	retur > AAE
2780 683 -5	Habbillns	2296-99	39457-99	1999	04-10-1999	2005	retur > AAE
2780 684 -3	Habbillns	2289-99	39450-99	1999	01-10-1999	2005	retur > AAE

Litra Habbins 1999

2771 700 - 764 1999 Niesky & TVP - fabriksnumre findes i vognlisten

= 65 godsvogne type H 99b - Indlejet fra AAE (AAE type H3)

Beskrivelse og historik

Bogieskydevægsvogne anskaffet i stort antal af AAE med udlejning for øje. DSB indlejede 1999 i alt 65 nybyggede vogne af AAE type H3. DSB gods havde muligvis overvurderet behovet for vognene, for allerede i 2001 overførtes 30 vogne til 53 CFR, i 2003 overførtes 25 vogne til 84 NS og de sidste 10 vogne overførtes i 2004 til 81 ÖBB.

Data**H 99b**

Længde over puffer	23264 mm
Understel længde	22024 mm
Bogiecenterafstand	17724 mm (b)
Bogier	Y25/TVP
Akselafstand bogie	1800 mm
Læselængde	22000 mm
Læsebredde	2840 mm
Bundfladeareal	62,5 m ²
Indv højde sidevæg	2100 mm
Indv højde gavlvæg	2800 mm
Rumfang	167,4 m ³
Sidedør bredde	2x 10810 mm
Sidedør højde	2800 mm
Gulvhøjde	1200 mm
Håndbremse	PS (a)
- bremsevægt	22,0 t
Automatisk bremse	KE-GP-A
- bremsevægt	Max 59t
Max hastighed	120 km/h
Taravægt ca	26500 kg
Lastgrænse UIC	

	A	B	C	D	
S	37,5	45,5	55,5	63,5	★★
120	0,00				

a) Det formodes, at alle vogne har P-skruebremse. Ihvertfald er ingen observeret uden.

b) Påmalet 17,70 m.

Vognliste

- se side **Habbins 1.51** ff

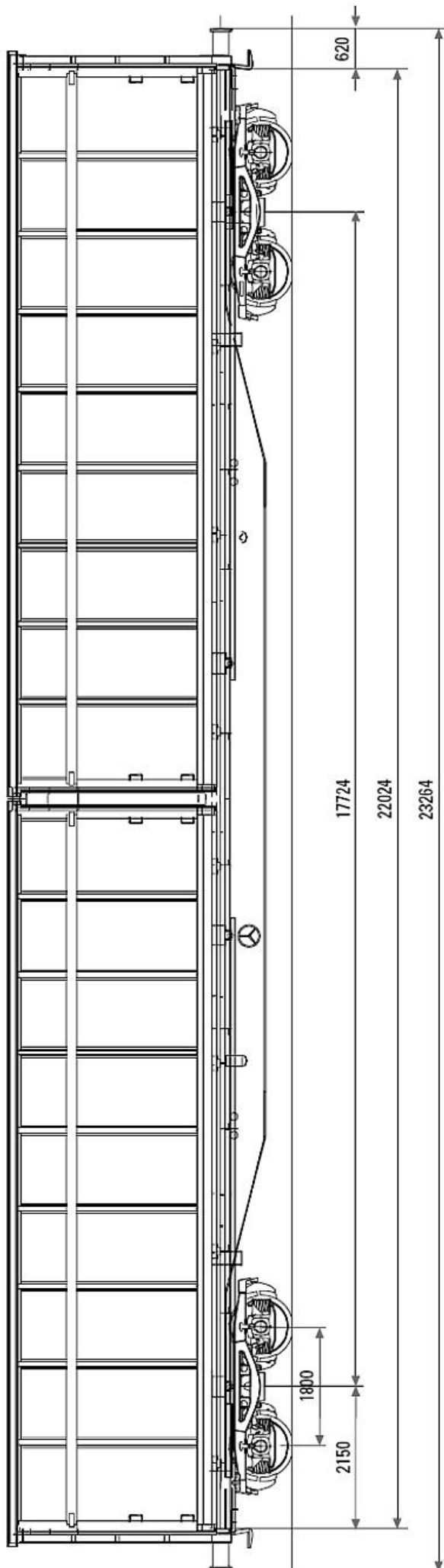

AAE type H3 - Tegning tilnærmet skala 1:87 / H0

fra http://www.aae.ch/upload/db_habbins.pdf

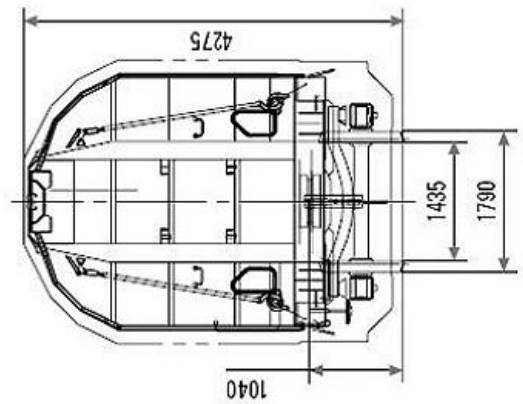



31 86 2771707-3 Habbins, Ringsted 06.09.2002 © Per Topp Nielsen



31 86 2771724-8 Habbins nyleveret, Fredericia Rbgd 07.08.1999 © Per Topp Nielsen



31 86 2771758-6 Habbins, København Gb 05.02.2000 © Per Topp Nielsen



31 86 2771733-9 Habbins nyleveret, Odense 07.08.1999 © Per Topp Nielsen

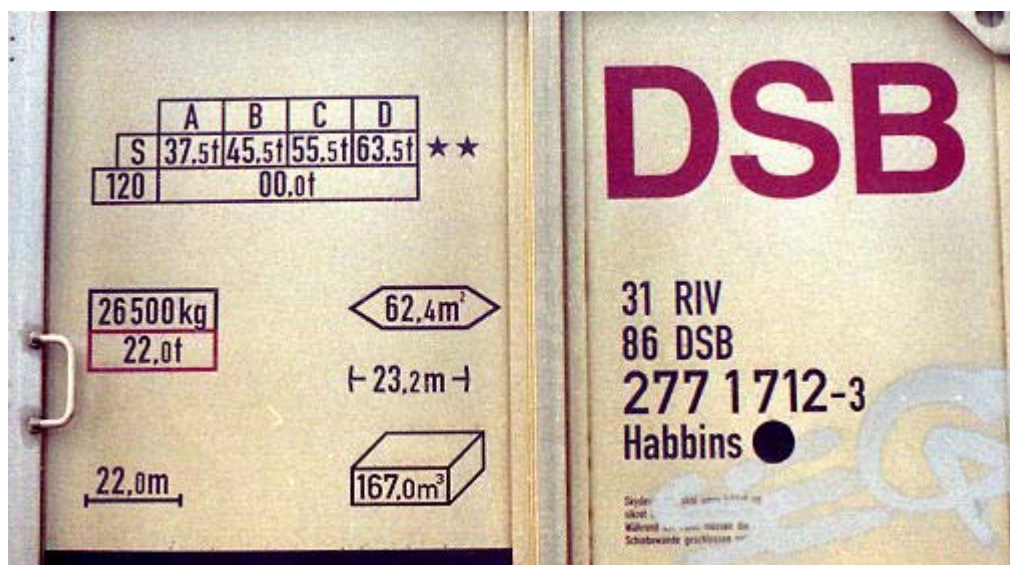

31 86 2771712-3 Habbins påskrifter, København Gb 22.07.2001 © Per Topp Nielsen

Hvad den sorte "klat" efter litra betyder, vides ikke.

31-86-	Litra	TVP	Niesky	tilg	REV	udg	senere
2771 700 -8	Habbins	2238	39399	1999	30-06-1999	2004	retur AAE > ÖBB
2771 701 -6	Habbins	2237	39398	1999	01-07-1999	2004	retur AAE > ÖBB > 81-2742815 Habbins 3 A-ÖBB
2771 702 -4	Habbins	2231	39392	1999	01-07-1999	2004	retur AAE > ÖBB
2771 703 -2	Habbins	2234	39395	1999	02-07-1999	2004	retur AAE > ÖBB
2771 704 -0	Habbins	2248	39409	1999	02-07-1999	2004	retur AAE > ÖBB > 81-2771704 Habbins 3
2771 705 -7	Habbins	2230	39391	1999	05-07-1999	2004	retur AAE > ÖBB > 81-2742171 Habbins A-ÖBB
2771 706 -5	Habbins	2209	39370	1999	05-07-1999	2004	retur AAE > ÖBB
2771 707 -3	Habbins	2235	39396	1999	06-07-1999	2004	retur AAE > ÖBB
2771 708 -1	Habbins	2229	39390	1999	06-07-1999	2004	retur AAE > ÖBB
2771 709 -9	Habbins	2188	39349	1999	07-07-1999	2004	retur AAE > ÖBB
2771 710 -7	Habbins	2253	39414	1999	08-07-1999	2003	retur AAE > NS
2771 711 -5	Habbins	2255	39416	1999	07-07-1999	2003	retur AAE > NS
2771 712 -3	Habbins	2258	39419	1999	08-07-1999	2003	retur AAE > NS
2771 713 -1	Habbins	2260	39421	1999	09-07-1999	2003	retur AAE > NS
2771 714 -9	Habbins	2259	39420	1999	09-07-1999	2003	retur AAE > NS
2771 715 -6	Habbins	2227	39388	1999	12-07-1999	2003	retur AAE > NS
2771 716 -4	Habbins	2243	39404	1999	12-07-1999	2003	retur AAE > NS
2771 717 -2	Habbins	2254	39415	1999	13-07-1999	2003	retur AAE > NS
2771 718 -0	Habbins	2224	39385	1999	13-07-1999	2003	retur AAE > NS > 84-2771718 Habbins 3 NL-RN
2771 719 -8	Habbins	2262	39423	1999	14-07-1999	2003	retur AAE > NS
2771 720 -6	Habbins	2217	39378	1999	14-07-1999	2003	retur AAE > NS
2771 721 -4	Habbins	2250	39411	1999	15-07-1999	2003	retur AAE > NS
2771 722 -2	Habbins	2261	39422	1999	15-07-1999	2003	retur AAE > NS
2771 723 -0	Habbins	2267	39428	1999	16-07-1999	2003	retur AAE > NS
2771 724 -8	Habbins	2246	39407	1999	16-07-1999	2003	retur AAE > NS
2771 725 -5	Habbins	2249	39410	1999	20-07-1999	2003	retur AAE > NS
2771 726 -3	Habbins	2268	39429	1999	19-07-1999	2003	retur AAE > NS
2771 727 -1	Habbins	2271	39432	1999	19-07-1999	2003	retur AAE > NS
2771 728 -9	Habbins	2266	39427	1999	20-07-1999	2003	retur AAE > NS
2771 729 -7	Habbins	2247	39408	1999	21-07-1999	2003	retur AAE > NS
2771 730 -5	Habbins	2273	39434	1999	21-07-1999	2003	retur AAE > NS
2771 731 -3	Habbins	2269	39430	1999	22-07-1999	2003	retur AAE > NS > 84-2771731 Habbins 3 NL-RN
2771 732 -1	Habbins	2241	39402	1999	22-07-1999	2003	retur AAE > NS
2771 733 -9	Habbins	2244	39405	1999	26-07-1999	2003	retur AAE > NS
2771 734 -7	Habbins	2278	39439	1999	23-07-1999	2003	retur AAE > NS
2771 735 -4	Habbins	2276	39437	1999	23-07-1999	2001	retur AAE > CFR
2771 736 -2	Habbins	2277	39438	1999	26-07-1999	2001	retur AAE > CFR
2771 737 -0	Habbins	2280	39441	1999	27-07-1999	2001	retur AAE > CFR
2771 738 -8	Habbins	2279	39440	1999	27-07-1999	2001	retur AAE > CFR
2771 739 -6	Habbins	2283	39444	1999	28-07-1999	2001	retur AAE > CFR
2771 740 -4	Habbins	2282	39443	1999	28-07-1999	2001	retur AAE > CFR
2771 741 -2	Habbins	2285	39446	1999	29-07-1999	2001	retur AAE > CFR
2771 742 -0	Habbins	2270	39431	1999	29-07-1999	2001	retur AAE > CFR
2771 743 -8	Habbins	2242	39403	1999	30-07-1999	2001	retur AAE > CFR
2771 744 -6	Habbins	2257	39418	1999	30-07-1999	2001	retur AAE > CFR
2771 745 -3	Habbins	2281	39442	1999	17-08-1999	2001	retur AAE > CFR
2771 746 -1	Habbins	2272	39433	1999	16-08-1999	2001	retur AAE > CFR
2771 747 -9	Habbins	2256	39417	1999	23-08-1999	2001	retur AAE > CFR
2771 748 -7	Habbins	2211	39372	1999	18-08-1999	2001	retur AAE > CFR
2771 749 -5	Habbins	2274	39435	1999	19-08-1999	2001	retur AAE > CFR

fortsættes

31-86-	Litra	TVP	Niesky	tilg	REV	udg	udg	senere
2771 750 -3	Habbins	2275	39436	1999	23-08-1999	2001	retur AAE > CFR	
2771 751 -1	Habbins	2265	39426	1999	20-08-1999	2001	retur AAE > CFR	
2771 752 -9	Habbins	2264	39425	1999	24-08-1999	2001	retur AAE > CFR > 80-2770795 Habbins 3 D-AAEC	
2771 753 -7	Habbins	2213	39376	1999	24-08-1999	2001	retur AAE > CFR	
2771 754 -5	Habbins	2290	39451	1999	25-08-1999	2001	retur AAE > CFR > 79-2770049 > 80-2770955	
2771 755 -2	Habbins	2288	39449	1999	25-08-1999	2001	retur AAE > CFR	
2771 756 -0	Habbins	2298	39459	1999	26-08-1999	2001	retur AAE > CFR	
2771 757 -8	Habbins	2245	39406	1999	01-09-1999	2001	retur AAE > CFR > 53-2771757 Habbins 3 RO-CFR	
2771 758 -6	Habbins	2252	39413	1999	03-09-1999	2001	retur AAE > CFR	
2771 759 -4	Habbins	2308	39469	1999	01-09-1999	2001	retur AAE > CFR > 80-2770796 Habbins 3 D-AAEC	
2771 760 -2	Habbins	2318	39479	1999	02-09-1999	2001	retur AAE > CFR	
2771 761 -0	Habbins	2310	39471	1999	02-09-1999	2001	retur AAE > CFR	
2771 762 -8	Habbins	2295	39456	1999	06-09-1999	2001	retur AAE > CFR	
2771 763 -6	Habbins	2300	39461	1999	03-09-1999	2001	retur AAE > CFR	
2771 764 -4	Habbins	2307	39468	1999	06-09-1999	2001	retur AAE > CFR	



31 53 RO-CFR 2771757-7 Habbins 3 med forstærkede døre. Creutzwald Ia Houve 09.03.2008 © Marc Schmitz